

Queue cône Morse
Morse taper shank
Mango
Cono Morse

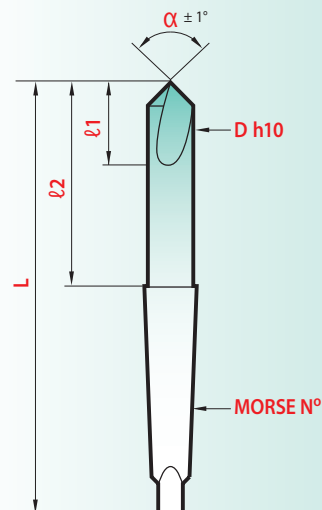

D		L		ℓ1		ℓ2		MORSE N°	90°	120°
h10	±1	±1	±1	±1	±1	±1	±1	N°	magafor 198	magafor 1906
10,0	130	25	64	1	€	90,77	€			
12,0	130	30	64	1		95,07			105,81	
16,0	148	35	68	2		117,09			131,06	
20,0	148	40	68	2		139,65			155,76	
25,0	171	45	72	3		192,29			212,70	

magafor



OUTILS MULTI-FONCTIONS
MULTI-FUNCTION TOOLS
HERRAMIENTAS MULTI-FUNCIÓN
UTENSILI MULTI-FUNZIONE

Promo-kits



6 COMBI-mag Ø 4 - 5 - 6 - 8 - 10 - 12
007 €147,17

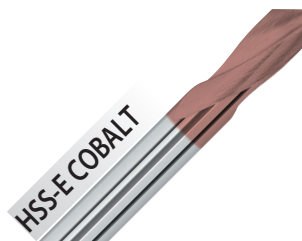

90°

COMBI-mag

D h7		L	ℓ	T*	Red'X 007
inch	mm	±1	+1		€
	3	50	6	0,3	16,65
1/8"	3,17	50	6	0,3	16,65
	4	52	8	0,4	17,19
3/16"	4,76	60	9	0,5	17,72
	5	60	10	0,5	17,72
	6	66	12	0,6	20,95
1/4"	6,35	66	12	0,6	22,02
5/16"	7,93	79	14	0,8	24,44
	8	79	14	0,8	24,44
3/8"	9,52	89	16	1	27,93
	10	89	16	1	29,00
	12	102	18	1,2	37,59
1/2"	12,7	102	19	1,3	39,74
	14	115	21	1,4	53,18
5/8"	15,87	115	24	1,6	55,33
	16	115	24	1,6	55,33

*T = 0,1 D Épaisseur d'âme Web thickness Espesor del núcleo Spessore in punta del nocciolo

COMBI-mag

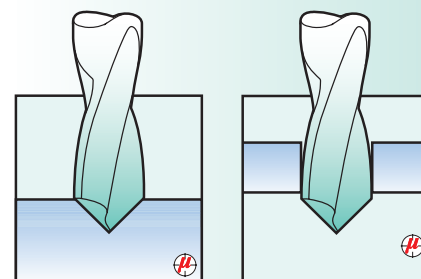

POINTAGE
SPOTTING
PUNTEADO
CENTRATURA

PERÇAGE
DRILLING
TALADRADO
FORATURA

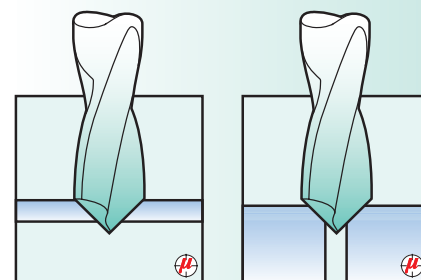

CHANFREIN DIRECT
DIRECT CHAMFER
CHAFLANES DIRECTOS
SVASATURA RAPIDA

CHANFREINAGE
COUNTERSINKING
AVELLANADO
SMUSSATURA

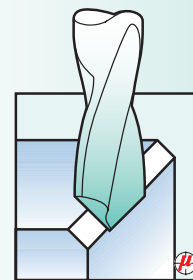

CHANFREIN LONGITUDINAL
LONGITUDINAL CHAMFER
CHAFLANES LONGITUDINALES
SMUSSI LONGITUDINALI