

FORETS À CENTRER 90°

90° CENTER DRILLS

BROCAS DE CENTRAR 90°

PUNTE A CENTRARE 90°

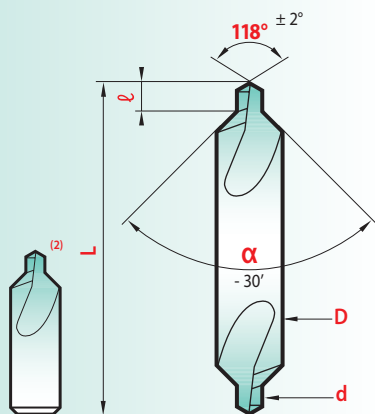

| D | d3 mini | l1 mini | l2 | magaforce 82X1 |
|------|------------|------------|-----|-------------------|
| 0,10 | 0,55 | 0,10 | 1,8 | € 34,91 |
| 0,15 | 0,55 | 0,15 | 1,8 | 34,38 |
| 0,20 | 0,55 | 0,20 | 1,8 | 33,84 |
| 0,25 | 0,85 | 0,25 | 2,7 | 33,30 |
| 0,30 | 0,85 | 0,30 | 2,7 | 32,23 |
| 0,40 | 1,4 | 0,40 | 4,5 | 31,15 |
| 0,50 | 1,4 | 0,50 | 4,5 | 31,15 |
| 0,60 | 2,3 | 0,60 | 7,2 | 31,15 |
| 0,80 | 2,3 | 0,80 | 7,2 | 31,15 |
| 1,00 | - | 1,00 | - | 31,15 |

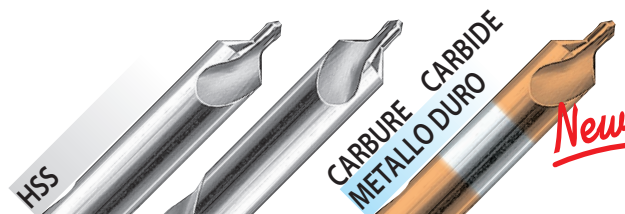

TYPE
TIPO

| D x d h7 ⁽¹⁾ k12 | L ± 1 | l mini maxi | magafor 15 | magafor 175 | Hard'X 8115-H |
|--------------------------------|----------|----------------|---------------|----------------|------------------|
| 3,0 x 0,5 ⁽²⁾ | 25 | 0,6 ~ 0,9 | € 13,69 | € | € |
| 3,5 x 0,75 | 35 | 1,0 ~ 1,3 | 12,36 | | |
| 4,0 x 1,0 | 35 | 1,3 ~ 1,7 | 11,28 | 35,99 | 67,14 |
| 5,0 x 1,5 | 40 | 2,0 ~ 2,6 | 11,54 | 38,67 | |
| 6,0 x 2,0 | 45 | 2,5 ~ 3,1 | 14,24 | 40,82 | 94,00 |
| 8,0 x 2,5 | 50 | 3,1 ~ 3,8 | 16,39 | 43,50 | |
| 8,0 x 3,0 | 50 | 3,9 ~ 4,6 | 16,39 | 43,50 | 115,49 |
| 10,0 x 3,0 | 55 | 3,9 ~ 4,6 | 21,22 | 49,95 | |
| 10,0 x 4,0 | 55 | 5,0 ~ 5,9 | 21,22 | 49,95 | 150,40 |
| 12,0 x 4,0 | 63 | 5,0 ~ 5,9 | 32,23 | | |
| 12,0 x 5,0 | 63 | 6,3 ~ 7,2 | 32,23 | | |
| 14,0 x 5,0 | 69 | 6,3 ~ 7,2 | 44,58 | | |
| 18,0 x 6,0 | 77 | 8,0 ~ 8,9 | 65,52 | | |
| 25,0 x 8,0 | 100 | 10,1 ~ 11,1 | 140,72 | | |

⁽¹⁾ CARBURE CARBIDE METAL DURO METALLO DURO = h5

⁽²⁾ 1 côté Single end De una sola punta Ad un solo lato

Longs Largas Serie Lunga

HSS-E COBALT

| D x d h7 k12 | L ± 1 | l mini maxi | magafor 188 |
|-----------------|----------|----------------|----------------|
| 4,0 x 1,0 | 120 | 1,3 ~ 1,7 | € 71,98 |
| 5,0 x 1,5 | 120 | 2,0 ~ 2,6 | 67,67 |
| 6,0 x 1,0 | 80 | 0,7 ~ 1,0 | 42,97 |
| 6,0 x 2,0 | 120 | 2,5 ~ 3,1 | 67,67 |
| 8,0 x 2,5 | 120 | 3,1 ~ 3,8 | 74,27 |
| 10,0 x 2,0 | 100 | 1,0 ~ 1,4 | 56,93 |
| 10,0 x 3,0 | 120 | 3,9 ~ 4,6 | 82,11 |
| 10,0 x 4,0 | 120 | 5,0 ~ 5,9 | 82,11 |
| 16,0 x 3,0 | 120 | 1,8 ~ 2,3 | 113,87 |